

GRAT•EX®

HAN-D-BURR®
COMFOR-D-BURR®

Entgrat-Systeme
Systèmes d'ébavurage
Sistemi sbavatori
Deburring Systems
Afgratnings systemer
Afgradnings system
Jäysteenpoistojärjestelmä
Affresnings systemer
Система Снятия Заусенцев
Systemy pro finální úpravu
Systemy do usuwania zadziorów
Sorjätlanító szisztéma
Çapak alma sistemleri
Sistemas de rebarba
Συστήματα αποκοκκάλωσης ψαριών
剔骨剔刺系統
מערכות עיבוד ליציקות מתכת
角扶除去システム
طرق استبعاد الشوك

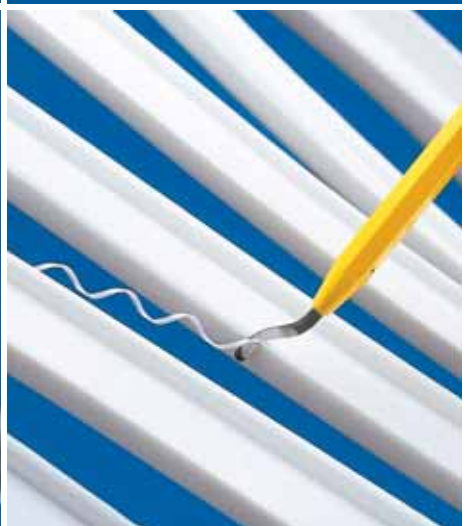



Entgratwerkzeuge für den perfekten Finish! Outils d'égavurage pour une finition parfaite!



mindestens
5- bis 10fache Standzeit

au moins 5 à 10 fois
plus de durabilité

MOVIC®

Beschichtung ist bestens geeignet für die Bearbeitung von Aluminium/Nickel/Kupfer/Edelmetalle sowie niedrig und höher legierten Stählen. Diese Beschichtung garantiert ausgezeichnete Gleiteigenschaften mit Anti-Klebneigung. Reibungs-Koeffizient unter 0.05!

MOVIC®

est un revêtement idéal pour l'usage de l'aluminium/nickel/cuivre/métaux précieux bien que pour les aciers faiblement et fortement alliés. MOVIC® est un revêtement «anti-collant» et possède un coefficient de frottement à sec inférieur à 0.05!

STARVIC®

ist eine mehrschichtige Verschleiss-Schutzschicht in Kombination mit einer MOVIC® Oberfläche. Dies ergibt beste Resultate bei abrasiven Werkstoffen, verstärkten Kunststoffen, hochlegierten Stählen, Titan, Platin etc. Die MOVIC® Deckschicht ergibt ausgezeichnete Gleiteigenschaften mit Anti-Klebneigung. Reibungs-Koeffizient unter 0.05!

STARVIC®

est un revêtement dur et auto-lubrifiant en combinaison. Ces caractéristiques donnent des résultats excellents pour l'usage des matériaux abrasives, plastiques renforcés, les aciers inoxydables, le titan, le platine etc. La surface MOVIC® est un revêtement «anti-collant» et possède un coefficient de frottement à sec inférieur à 0.05!

B

Rotierende Klingen Ø 2.6 mm

Lames rotatives Ø 2.6 mm

GRAT•EX® Set B
B10/B20/B30/B60

2-1003

CHF



HAN-D-BURR® Set B MOVIC®
B10 MOVIC®/B20 MOVIC®

2-428

CHF

best choice

**E**

Rotierende Klingen Ø 3.2 mm

Lames rotatives Ø 3.2 mm

GRAT•EX® Set E
E100/E200/E300/E600

2-1006

CHF



GRAT•EX® Set 69
E100/E200/E300

2-1002

CHF



AZ Set 201
E100 STARVIC®
ALU-Handgriff/Manche ALU

36-7080-201 CHF

a special touch



HAN-D-BURR® Set E MOVIC®
E100 MOVIC®/E200 MOVIC®

2-268

CHF

coated blades



GRAT•EX® MB
E100, auswechselbar/interchangeable
ALU-Handgriff/Manche ALU

2-1020

CHF



GRAT•EX® UB
E100, fix/fixe
ALU-Handgriff/Manche ALU

2-1030

CHF



AZ Set 211
2-557 STARVIC®
auswechselbar/interchangeable
ALU-Handgriff/Manche ALU

36-7080-211 CHF

a special touch

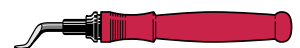

COMFOR-D-BURR® E micro
2-550, fix/fixe

2-1037

CHF

for fine jobs



HAN-D-BURR® Set E mini
2-550/2-560

2-210







CHF

very handy







C

Schaber Grattoir

GRAT•EX® Set C C42/C40	# 2-1004	CHF	
AZ Set 230 36-7080-750 ALU-Handgriff/Manche ALU	# 36-7080-230	CHF	 Alu handle
COMFOR-D-BURR® C micro fix/fixe	# 2-1033	CHF	 for fine jobs
HAN-D-BURR® Set C mini 2-500/2-510	# 2-220	CHF	
HAN-D-BURR® Set C midi 2-404	# 2-400	CHF	
HAN-D-CUT Ceramic 2 x 2-720	# 2-920	CHF	 new generation

G

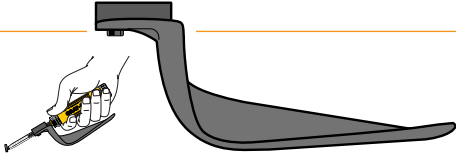
Nuten entgraten / Nuten anfasen Ebavurage rainures

GRAT•EX® Set G G70/G80, 1,2–11 mm	# 2-1009	CHF	
GRAT•EX® Set I 2-1011-60/2-1011-50	# 2-1011	CHF	
GRAT•EX® Handschutz zu Set G/I Protège-main pour Set G/Set I	# 2-1900	CHF	
HAN-D-BURR® Set G 2-570 für Nuten/pour rainures 1–3 mm	# 2-450	CHF	

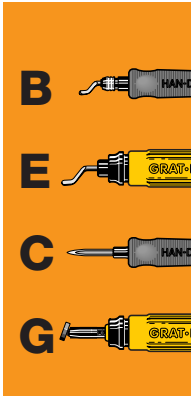

F

Senken/Anfasen Fraisage intérieur/extérieur

GRAT•EX® Set F
F20, Ø 1–20 mm

2-1007

CHF



GRAT•EX® Set FR
F20, Ø 1–20 mm

2-1008

CHF



GRAT•EX® Set KU
F30, Ø 1–30 mm
* Rotodrive pat.

2-1013

CHF

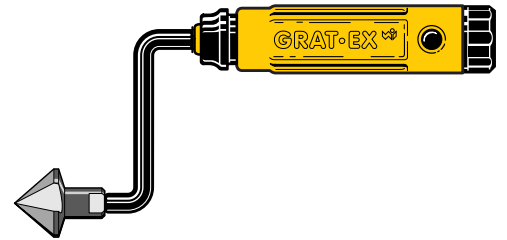

COMFOR-D-BURR® KU micro
2-630, Ø 0,4–3 mm
* Rotodrive pat.

2-1032

CHF



HAN-D-BURR® Set KU midi
2-620, bis/jusqu'à Ø 10,4 mm
* Rotodrive pat.

2-240

CHF



HAN-D-BURR® Set A
2-318, Ø 5–18 mm
* Rotodrive pat.

2-305

CHF



**HAN-D-BURR® Umdrehsenker/
Chanfreinage reversible/pat.**
2-1014-30, Ø 10–22 mm

2-1014-3

CHF

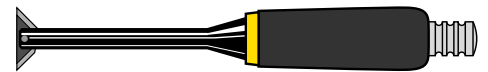

**HAN-D-BURR® Umdrehsenker/
Chanfreinage reversible/pat.**
2-1014-20, Ø 5,5–10 mm

2-1014-2

CHF



**HAN-D-BURR® Umdrehsenker/
Chanfreinage reversible/pat.**
2-1014-10, Ø 3–5,5 mm

2-1014

CHF



* Rotodrive = Kurbelentgraten ohne nachfassen!
= ébavurage vilebrequin !

D/L

Blechentgrater/Kantenbrecher Ebavurage à tôle/Ebavurage arêtes rectiligne

GRAT•EX® Set D80
D80 HM, bis/jusqu'à 3,5 mm

2-1005 CHF



GRAT•EX® Set D85
D85 HSS, bis/jusqu'à 5 mm

2-1005-1 CHF



GRAT•EX® Set D30
D30 HSS/D40 HSS, bis/jusqu'à 8 mm

2-1005-3 CHF



GRAT•EX® Set L

2-1012 CHF



GRAT•EX® Handschutz zu Set D/L
Protège-main pour Set D/Set L

2-1900 CHF

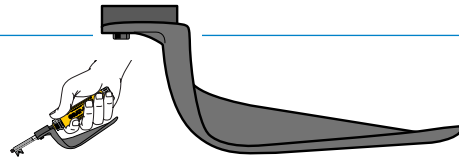

GRAT•EX® Set D100
2-1010-80, bis/jusqu'à 12 mm

2-1005-100 CHF

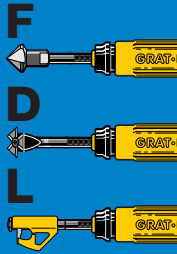
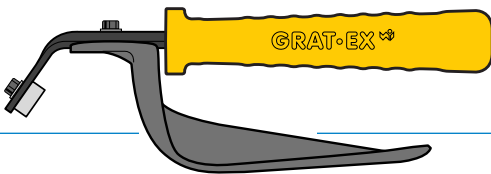

Werkzeug-Kombinationen

Combinations d'outils

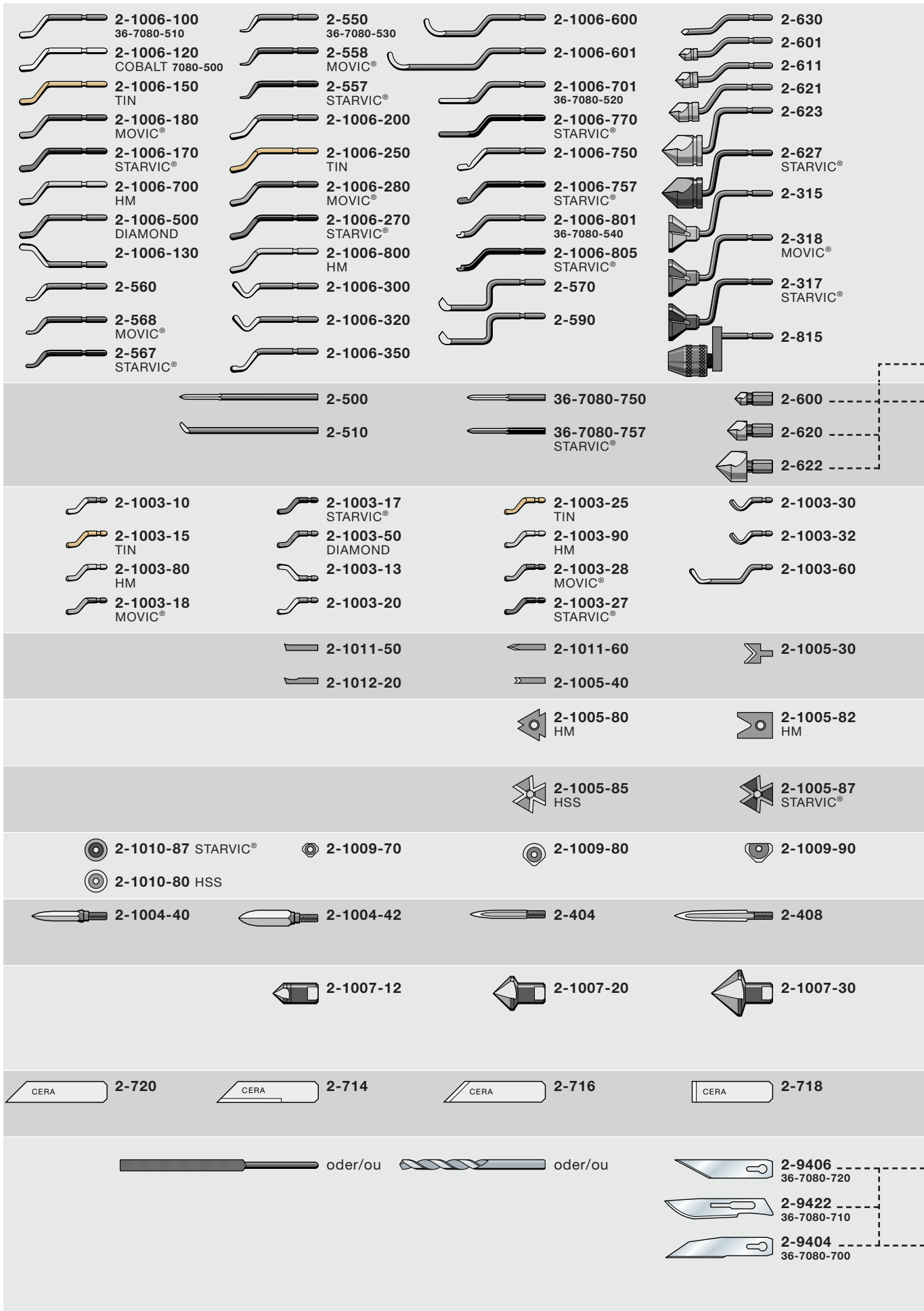



 2-1001-6 CHF

 2-80 CHF

 2-1000-5 CHF

 2-1020-1 CHF

 2-55-1 CHF

 2-90 CHF

 2-95 CHF

 2-1001-3 CHF

 2-1000 CHF

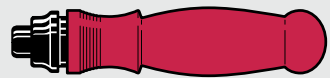
 36-7080-200 CHF

 36-7080-210 CHF

 2-50-1 CHF

 36-7080-230 CHF

 2-57 CHF

 2-1001-30 CHF

 2-1001-12 CHF

 2-1001-5 CHF

 2-1001-85 CHF

 2-1001-9 CHF

 2-1001-4 CHF

 2-56 CHF

 2-1001-8 CHF

 2-1001-7 CHF

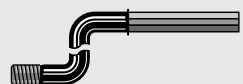
 2-1001-13 CHF

 2-63-1 CHF

 2-40-1 CHF

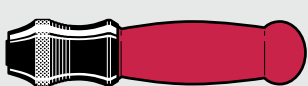
 36-7080-220 CHF
bis/jusqu'à
Ø 5 mm

Handgriffe
Manches
Stahlhalter
Porte-outils

Kombinationen
Combinaisons

Anwendung Utilisation

Artikel-Nummer
Numéro d'article

Verpackungseinheit
La boîte de
CHF/Stück
CHF/pièce
Stahl gehärtet
Acier trempé
Hartmetall/Glas
Carbure/verre
Stahl/Kupfer/Alu
Acier/cuivre/alu
Messing/Guss
Laiton/fonte
Rostfreie Stähle
Acier inoxydable
Polyacetal/Polyamide
PVC

Rotierende Klingen/Lames rotatives

Icon	Artikel-Nummer / Numéro d'article	Verpackungseinheit / La boîte de	Stahl gehärtet / Acier trempé	Hartmetall/Glas / Carbure/verre	Stahl/Kupfer/Alu / Acier/cuivre/alu	Messing/Guss / Laiton/fonte	Rostfreie Stähle / Acier inoxydable	Polyacetal/Polyamide	PVC
	2-1003-10	10							
	2-1003-15 TIN	10							
	2-1003-80 HM	10							
	2-1003-18 MOVIC®	10							
	2-1003-17 STARVIC®	10							
	2-1003-50 DIAMOND	1							
	2-1003-13	10							
	2-1003-20	10							
	2-1003-25 TIN	10							
	2-1003-90 HM	10							
	2-1003-28 MOVIC®	10							
	2-1003-27 STARVIC®	10							
	2-1006-100 36-7080-510	10							
	2-1006-120 COBALT 36-7080-500	10							
	2-1006-150 TIN	10							
	2-1006-180 MOVIC®	10							
	2-1006-170 STARVIC®	10							
	2-1006-700 HM	10							
	2-1006-500 DIAMOND	1							
	2-1006-130	10							
	2-560	10							
	2-568 MOVIC®	10							
	2-567 STARVIC®	10							
	2-550 36-7080-530	10							
	2-558 MOVIC®	10							
	2-557 STARVIC®	10							
	2-1006-200	10							
	2-1006-250 TIN	10							
	2-1006-280 MOVIC®	10							
	2-1006-270 STARVIC®	10							
2-1006-800 HM	10								
2-1006-350	10								
	2-1003-30	10							
	2-1003-32	10							
	2-1003-60	10							
	2-1006-300	10							
	2-1006-320	10							
	2-1006-600	10							
	2-1006-601	10							
	2-1006-750	10							
	2-1006-757 STARVIC®	10							
	2-1006-801 36-7080-540	10							
	2-1006-805 STARVIC®	10							

Populäre Klingen / Lames populaires

Erste Wahl / Premier choix
 Zweite Wahl / Deuxième choix
 Dritte Wahl / Troisième choix

Anwendung Utilisation









Artikel-Nummer
Numéro d'article

Verpackungseinheit
La boîte de
CHF/Stück
CHF/pièce























Artikel-Nummer
Numéro d'article

Verpackungseinheit
La boîte de
Preis/Stück
Prix/pièce







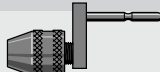









Nuten entgraten, anfasen/Ebavurage rainures

		2-1009-70 1,2–8 mm	10			2-570 1–3 mm	5
		2-1009-80 2,4–11 mm	10			2-590	5
		2-1009-90 3–15 mm	6				















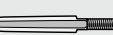

Senken, Anfasen/Fraisage intérieur, extérieur

		2-1007-12 Ø 12 mm	1			2-630 Ø 3,2 mm	5
		2-1007-20 Ø 20 mm	1			2-601 Ø 6,3 mm	1
		2-1007-30 Ø 30 mm	1			2-611 Ø 8,3 mm	1
		2-600 Ø 6,3 mm	1			2-621 Ø 10,4 mm	1
		2-620 Ø 10,4 mm	1			2-623 Ø 16,5 mm	1
		2-622 Ø 16,5 mm	1			2-627 STARVIC® Ø 16,5 mm	1
		2-1014-30 Ø 10–22 mm	1			2-315 Ø 5–18 mm	1
		2-1014-20 Ø 5,5–10 mm	1			2-318 MOVIC®	1
		2-1014-10 Ø 3–5,5 mm	1			2-317 STARVIC®	1
		2-815	1				

Blechentgraten, Kantenbrechen/Ebavurage à tôle, ébavurage arêtes rectiligne

		2-1005-80 D80 HM, <3,5 mm	10			2-1005-40 0–2,5 mm	10
		2-1005-82 D82 HM, <8 mm	10			2-1005-30 1–8 mm	10
		2-1005-85 D85 HSS, <5 mm	10			2-1011-50	10
		2-1005-87 D85 STARVIC®	5			2-1012-20	10
		2-1010-80 HSS	10			2-1011-60	10
		2-1010-87 STARVIC®	10				

Schaben/Gratter

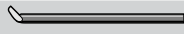
		2-1004-40 C40, 4 mm	10			2-404 4 mm	5
		2-1004-42 C42, 8 mm	10			2-408 8 mm	5
		2-500 Ø 3,2 x 75 mm	10			2-1006-701 36-7080-520	10
		36-7080-750 Ø 3,2 x 50 mm	4			2-1006-770 STARVIC®	10
		36-7080-757 STARVIC®	4				
		2-510 Ø 3,2 x 73 mm	10				

Ersatzklingen
Lames

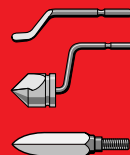

Anwendung
Utilisation
STARVIC®
MOVIC®

Ceramic

Artikel-Nummer
Numéro d'article
Verpackungseinheit
La boîte de
CHF/Stück
CHF/pièce

Artikel-Nummer
Numéro d'article
Verpackungseinheit
La boîte de
CHF/Stück
CHF/pièce

Schneiden/Lames couteaux d'ébavurage Ziehklinge/Lame à ébavurer

		2-714	1	CHF		2-720	1	CHF
		2-716	1	CHF		Spezielle Formgebung ist mit DIAMOPRO-Schleifscheiben möglich. Pour réaffûter la lame, demandez la meule spéciale DIAMOPRO.		
		2-718	1	CHF				

Die neue Generation Entgratwerkzeuge mit Keramikklingen.

Ziehklingen zum Entgraten, Schaben, für den perfekten Finish an Kunststoffen aller Art, Plexiglas, Verbundstoffen etc.

Kein unerwünschtes Einschneiden, gleichmässige Oberflächenqualität dank 0°-Schneidwinkel.

Regelmässiger Materialabtrag ohne Gefahr für das Werkstück.

Die Ziehklinge eignet sich ebenfalls sehr gut für einen regelmässigen Kantenbruch nach dem Schleifen gehärteter Teile. Feinentgraten von Aluminium, Buntmetallen, Chromstahl etc. Mit wenig Druck arbeiten. Lange Lebensdauer dank mehrerer Schneidkanten. Die Klingen sind im Spanngriff einfach auswechselbar. Messerklingen zum Schneiden von Gummi, Schaumstoffen, Kunststofffolien, Laminaten, Papier etc.

Achtung! Bei zuviel Seitendruck auf die Messerklingen besteht Bruchgefahr. Die Klingen immer mit möglichst wenig Überstand einspannen.

La dernière technologie à la pointe en matière de cutters et d'ébavureurs.

Lames à ébavurer, gratter, pour une finition parfaite de plastique, plexi, matériaux composites etc.

La coupe de la lame céramique à 0° n'incite pas l'ébavureur à entrer dans la matière.

L'enlèvement de matière est régulier, sans risque de détériorer la pièce à ébavurer.

La lame à ébavurer est excellente pour une finition régulière des aciers trempés après rectification. Ebavurage fin de l'aluminium, le non-ferreux, l'inox etc. Vous trouverez vous-même votre application. Matière résistante, évitez trop de pression et les chocs.

Lames interchangeable dans manche polyvalent. Lames couteaux pour matières plastiques, toutes sortes de feuillets, film, le caoutchouc, les mousses etc.

Un conseil: Evitez d'exercer une trop grande pression latérale, si vous voulez préserver votre lame couteau.







Stahlmesser Lames couteaux acier

Artikel-Nummer
Numéro d'article
Verpackungseinheit
La boîte de
CHF/Stück
CHF/pièce

Artikel-Nummer
Numéro d'article
Verpackungseinheit
La boîte de
CHF/Stück
CHF/pièce

Schneiden/Lames couteaux d'ébavurage

		2-9406 36-7080-720	10	CHF			2-9422 36-7080-710	10	CHF
		2-9404 36-7080-700	10	CHF					

Sets

**GRAT•EX®
COMPLET-SET 2-1600**

CHF

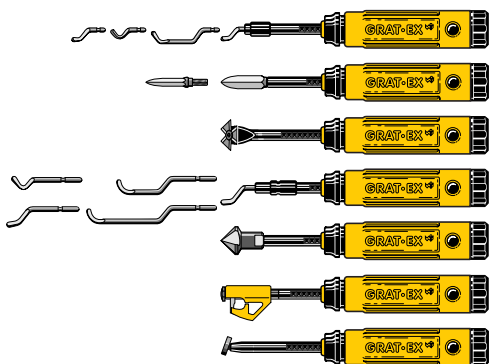

**HAN-D-BURR®
SET 2-204**

CHF

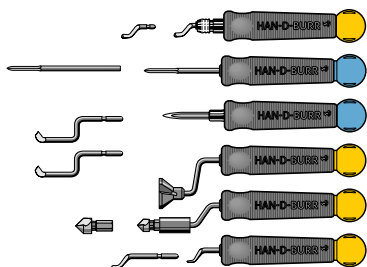

**AZ-CCK
SET 36-7080**

CHF

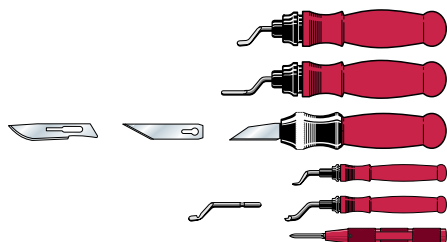

a special touch

Alu handles



CERAMIC



Sets



Sets

GRAT•EX®
TRI SET 2-1100

CHF

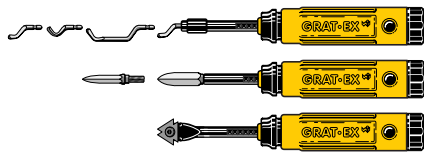

GRAT•EX®
MASTER SET 2-1200

CHF

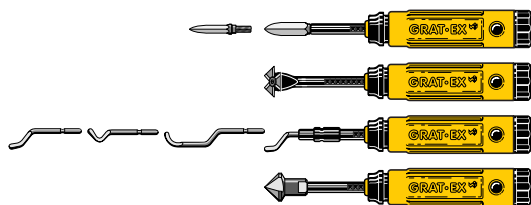

GRAT•EX®
MEC SET 2-1400

CHF

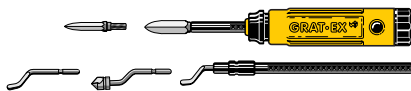

GRAT•EX®
BLECH/TÔLE SET 2-1500

CHF

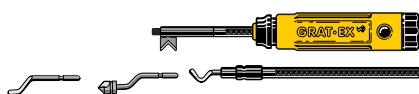

**COMFOR-D-BURR®
SET 2-1031**

CHF



**HAN-D-BURR®
SET 2-202**

CHF

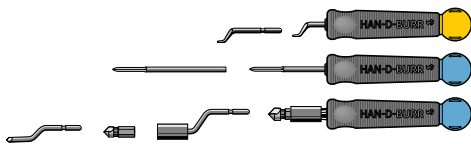

**HAN-D-CUT®
CERAMIC SET 2-930**
Vickers hardness (HV 500 g)

CHF

1300-1500

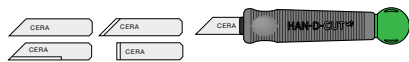

**HAN-D-CUT®
SET 2-911**
STAHLMESSER/LAME ACIER

CHF



Sets





Jakob AG
Qualitäts-Werkzeuge
Postfach 458
CH-8630 Rüti
Tel. +41 (0)55 240 27 79
Fax +41 (0)55 240 66 30

all@jakob-ag.ch
www.jakob-ag.ch

